



**Safety, Health & Welfare Policy
&
Safety Statement**

Re-evaluated and ratified by Board of Management

Date _____

Chairperson to Board of Management: Malachy Molloy

Signed by Chairperson of the Board:

Safety, Health & Welfare Policy

In accordance with The Safety, Health and Welfare Act 2005, it is the policy of the Board of Management to ensure, so far as is reasonably practicable, the safety, health and welfare at work of all staff (teaching and non-teaching) and to protect pupils, visitors, contractors and other persons at the school from injury and ill health arising from any work activity. The successful implementation of this policy requires the full support and active co-operation of all staff, contractors, visitors, parents/guardians and pupils of the school.

It is recognized that hazard identification, risk assessment and control measures are legislative requirements which must be carried out by the employer to ensure the safety, health and welfare of all staff.

The Board of Management, as employer, undertakes in so far as is reasonably practicable to:

- a. Promote standards of safety, health and welfare that comply with the provisions and requirements of the Safety, Health and Welfare at Work Act 2005 and other relevant legislation, standards and codes of practice;
- b. Provide information, training and instruction and supervision where necessary, to enable staff to perform their work safely and effectively;
- c. Maintain a constant and continuing interest in safety and health matters pertinent to the activities of the school;
- d. Continually improve the system in place for the management of occupational safety and health and review it periodically to ensure it remains relevant, appropriate and effective;
- e. Consult with staff on matters related to safety, health and welfare at work;

- f. Provide the necessary resources to ensure the safety, health and welfare of all those to whom it owes a duty of care, including staff, pupils, contractors and visitors.

The Board of Management is committed to playing an active role in the implementation of this occupational safety and health policy and undertakes to review and revise it in light of changes in legislation, experience and other relevant developments.

Signed:

Chairperson, Board of Management

School: Coláiste Muire Ballymote

Date:

School Profile

Coláiste Muire is a co-educational post-primary school under the patronage of CEIST (Catholic Education an Irish Schools Trust). Approximately 320 pupils attend daily along with 30 staff.

School planning procedures involve consultation with all the main partners of the school including the staff, the students via the Students' Council, the parents via the Parents' Association and the Board of Management.

Coláiste Muire welcomes and makes provision where possible for persons with special needs. The school's Additional Educational Needs policy details the supports available for students with additional educational needs. The Board of Management will ensure that places of work, where necessary, are organised to take account of persons at work with disabilities. An evaluation of the disability needs for the person will be done in consultation with the person, his/her GP and in the case of a student, with the aid of the student's care plan and in consultation with his/her parent(s)/guardian(s).

The map in Appendix A details the layout of the school buildings along with the facilities, emergency exits, fire assembly points and one-way system.

The school's organizational/structure chart is as follows:

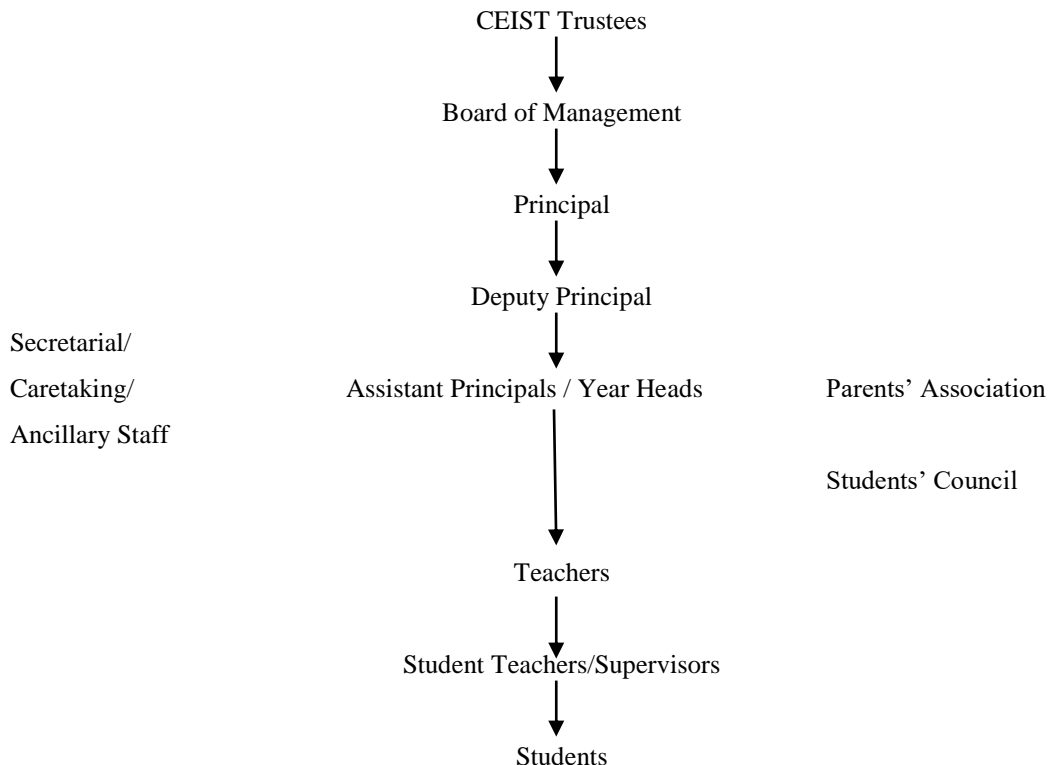

The following regular visitors provide services to the school (this list is not exhaustive):

- External tutors for Transition Year, e.g. History & Genealogy tutor, LawEd tutor, Driving instruction tutor, etc.
- Charitable organization speakers
- Building contractors and maintenance
- HSE to provide vaccination services
- Fire safety systems management
- CCTV maintenance crew
- Security alarm maintenance
- Drainage and water services
- Electricity meter reading staff
- Refuse collection
- Canteen service delivery
- Contract cleaning staff
- Priests and members of other religious denominations from the locality for masses and other liturgical services
- Sports coaches (GAA/LGFA/IRFU/FAI/Basketball Ireland, etc.)
- Couriers and An Post

There is a relationship between the school's taught curriculum and the safety statement. Curriculum areas where safety is taught include:

- Wellbeing
- Social, Personal and Health Education
- Materials Technology (Wood) & Construction Studies
- Science
- Physical Education
- Art, Craft and Design
- Home Economics
- Field trips and educational visits in e.g. Geography, History, Civic, Social and Political Education
- Transition Year Choose Safety module
- Leaving Certificate Vocational Programme modules
- Agricultural Science
- Design and Communication Graphics

Resources to be applied

The Board of Management will ensure that appropriate resources are allocated to support safety, health and welfare in the school. The school has a health and safety representative (the Principal) to ensure the health, safety and welfare of staff, students and others in the school community. Staff including ancillary staff are provided with the necessary equipment and training to allow them conduct their work in a safe manner.

Roles & Responsibilities

Board of Management

The Board of Management has overall responsibility for ensuring effective health and safety management.

Its main responsibilities are:

- Compliance with its legal obligations as employer under the 2005 Act.
- Providing a safe place of work and safe systems of work.
- Ensuring that written risk assessments are completed in the school and that the safety statement is up-to-date.
- Receiving regular reports on safety and health matters.
- Reviewing the safety statement at least annually and when changes occur that might affect safety, health and welfare.
- Reviewing the school's performance in relation to safety, health and welfare.
- Allocating adequate resources to deal with safety, health and welfare issues.
- Appointing competent persons as necessary to advise and assist the Board of Management on safety, health and welfare matters at the school.

Designated person for safety, health and welfare acting on behalf of the Board of Management, e.g.

Principal/Deputy Principal

Safety begins at management level and so the overall responsibility for the establishment and maintenance of an effective policy for Safety, Health and Welfare at work rests with the Principal in conjunction with the Board of Management. Obligations under the Safety, Health and Welfare at Work Act 2005 will rest mainly with the Principal. These duties will fall to the Deputy Principal in the absence of the Principal.

The Principal will:

- Ensure compliance with the requirements of the 2005 Act.
- Report to the Board of Management on the school's performance in relation to safety, health and welfare.
- Manage safety, health and welfare in the school on a day-to-day basis.
- Try to ensure that there are available, sufficient funds and facilities to enable the safety policy to be implemented.
- Communicate regularly with all members of the school community on safety, health and welfare matters.

- Ensure all accidents and incidents are investigated and all relevant statutory reports completed.
- Manage the development and regular practice of emergency procedures.
- Identify staff training needs and organise relevant training.
- Ensure that risk assessments and corrective actions are carried out.
- Ensure that regular reviews of the school's performance in relation to safety, health and welfare are carried out.
- Ensure that safety considerations are observed by any contractors working within the school.
- Ensure that the Safety Statement is available to, and read by, all staff and appropriate third parties.

Teaching & Other staff

Employees have general statutory obligations under the Safety, Health and Welfare at Work Act 2005. All employees must:

- Comply with all statutory obligations on employees as required by the 2005 Act.
- Co-operate with school management in the implementation of the safety statement.
- Inform students of the safety procedures associated with individual subjects.
- Ensure that students follow safe procedures, e.g. use personal protective equipment (PPE) and adhere to laboratory/practical room rules.
- Conduct risk assessments of their immediate work environment.
- Formally check classroom/immediate work environment to ensure it is safe and free from fault or defect.
- Check that equipment is safe before use.
- Ensure that risk assessments are conducted for new hazards, e.g. new machine, system or chemical product.
- Select and appoint a safety representative(s).
- Co-operate with the school safety committee, where applicable.
- Report accidents, near misses, and dangerous occurrences to relevant persons as outlined in the safety statement.
- Take reasonable care of their own safety, health and welfare and any other person who may be affected by their actions or omissions at work.
- Co-operate with the Board of management, Principal and any other person, in order to comply with any of the relevant statutory provisions.
- Use the safety equipment provided, or other items provided for their safety, health and welfare at work.
- Report to the Principal, without delay, any defects in equipment, place of work or systems of work, which might create a danger to the safety, health and welfare of themselves and others.

Students

All students must:

- Take reasonable care of their own health, safety and welfare and that of any other person who may be affected by their actions at school or on/during school activities/outings.
- Co-operate with the Principal, Deputy Principal, teachers and ancillary staff in order to comply with health and safety legislation.
- Report to subject teachers any defects in equipment in classrooms which might create danger.
- Not intentionally or recklessly interfere with or mis-use any appliance or safety equipment provided.
- Not partake in any form of dangerous pranks or unauthorized hazardous activities.
- Keep work areas clean.
- Be careful when moving items.
- Not run on floors/corridors/steps.
- Not leave school without permission during school hours.
- Not leave bags on corridors.
- Not smoke on school premises.
- Not use alcohol or illegal substances while at school or partaking in school activities/outings.
- Not use mobile phones/camera phones/cameras/IPods/MP3 players, etc. during school day unless directed for use by a member of staff.
- Follow the school policy on wearing jewellery and uniform.
- Follow procedures as per the fire drill and safety check lists in the appendices.

Parents

Parents must:

- Ensure students are not wearing jewellery and are not equipped with mobile phones as per the school's code of behaviour.
- Collect children as required due to illness.
- Fulfill roles as per school's code of behaviour.

Other school users

Coláiste Muire has a responsibility to ensure, as far as it is reasonably practicable, the safety of visitors and volunteers while on the site. To that end the following policies will apply:

- All visitors/volunteers to report to the Secretary's Office
- Volunteers and visitors have a duty to comply with school regulations and instructions relating to safety, health and welfare.

Contractors

Any contractor working in or on behalf of the school has a duty to comply with statutory obligations as designated under the Safety, Health and Welfare at Work Act 2005, the Safety, Health and Welfare at

Work (General Application) Regulations 2007-2016, and any other relevant legislation such as the Safety, Health and Welfare at Work (Construction) Regulations 2013. For the purposes of the safety statement the school will:

- Make available the relevant parts of its safety statement and safety file (where one exists) to any contractors working in the school on behalf of the school.
- Provide to contractors the school's regulations and instructions relating to safety, health and welfare.
- Be aware of the contractor's duty to make available to the school the relevant parts of the contractor's safety statement and risk assessments in relation to the work being carried out.
- Co-operate and coordinate their activities in order to prevent risks to safety, health and welfare where it is sharing a workplace with a contractor.

The school has a duty as a client if they engage a contractor to carry out construction work, e.g. where a school is getting construction work carried out, they will have duties as a Client under the Safety, Health and Welfare at Work (Construction) Regulations, 2013. These duties include:

- appointing competent designers and contractors
- appointing competent Project Supervisors for the Design Process (PSDP)
- appointing competent Project Supervisors for the Construction Stage (PSCS) where:
 - there is more than one contractor involved in the work
 - the work is scheduled to last more than 30 days (or 500 person days), or
 - there is a particular risk involved
- notifying the Health and Safety Authority if the work is scheduled to last more than 30 days (or 500 person days) using the AF1 Form available on www.hsa.ie.

Contractors will not be permitted on the premises to carry out work until the School Principal or designated representative has checked and is satisfied with their insurances. The contractor must liaise with a School-appointed official and discuss and agree the safety precautions deemed necessary by either party. Contractors must take all due care of their own safety, the safety of their employees and all others affected by their work. Contractors must not use any equipment or the service of personnel belonging to or engaged by the School Board without prior approval being granted by the School-appointed official. Every contractor working on School premises must comply with all applicable statutory requirements, best industry practices and any special safety rules or conditions imposed by the school. In this regard, it is the responsibility of the contractor to:

- Provide all necessary instruction, training and information on health and safety matters to their employees.
- Provide competent and adequate supervision of their employees and activities.
- Provide all necessary safety equipment and clothing for their employees.

- All plant and equipment brought onto the School site must be safe and in good working order and with any necessary certificates available for checking.
- Ensure that all accidents and dangerous occurrences are reported to the School Principal.
- Ensure that all school safety notices and alarms are followed at all times.
- Ensure that hazardous substances are not brought on to the premises without prior notice and permission.
- Ensure that 'approved' hazardous substances are stored and used safely whilst on the premises.
- Ensure that all hazardous substances are removed from the premises.
- Monitor and assess the safety performance of their employees.
- Ensure their employees are not working under the influence of alcohol or illegal substances.
- The degree of risk assessment that must be carried out before work begins will depend on the nature and extent of activities associated with each individual contract.

Self-Employed Persons

All self-employed persons shall provide their safety statement when requested to do so and shall:

- Confirm generally with the duties and responsibilities as for employees.
- Provide evidence when requested, showing that appropriate employer's liability and public liability insurances are in place.
- Bring to the attention of the Principal, DSO and anyone else who may be affected by any process or use of materials, which may endanger health and safety while at work.
- Comply with the requirements of this safety statement, and co-operate with the Board of Management in providing a safe place at work and a safe system of operation.
- Ensure all their employees and others under their care are provided with and wear protective clothing and equipment appropriate to the task.
- Report any defect in the plant and equipment, place of work, or system of work without unreasonable delay.
- Only use competent and suitable persons on site.
- Obtain the consent of the Principal before engaging persons other than their direct employees on site.
- Ensure that their managers, supervisors and employees are aware of the obligations placed upon them with regard to health and safety.

Safety Representative

The role or function of the safety representative is to consult and make representations to the Principal or the Board of Management on safety, health and welfare matters relating to colleagues (including non-teaching staff) in the school. The Principal is currently the Safety Representative for the school.

The safety representative, having given reasonable notice to the Board of Management, has the right to inspect all or part of the school and immediately if there is an accident or dangerous occurrence or

imminent danger or risk to safety and to investigate accidents and dangerous occurrences. Safety representatives may also:

- after giving notice to the Board of Management, investigate complaints relating to health and safety
- make representations to Health and Safety Authority Inspectors
- accompany Health and Safety Authority Inspectors carrying out inspections (except following an accident, although this may be allowed at the discretion of the Inspector)
- If a Health and Safety Authority Inspector is carrying out an inspection, the Board of Management must inform the safety representative. This can be done by the Principal, acting on behalf of the Board of Management.

Safety representatives are entitled to time-off work, without loss of remuneration, to discharge their functions and to be trained for their role. There are no duties associated with the safety representative but there are rights and functions. These are listed in the 2005 Act and outlined in The Safety Representatives Resource Book and Guidelines on Safety Representatives on www.hsa.ie. A short awareness-raising course is available online free of charge for safety representatives on <https://hsalearning.ie>.

Risk Assessments

Risk assessment is at the heart of managing safety, health and welfare effectively in the workplace. When addressing risk assessments, all members of the school community will be familiar with the following health and safety term:

- **Hazard:** A hazard is anything that has the potential to cause harm to people, property or the environment. It can be a work material, work equipment, or a work method or practice.
- **Risk:** Risk is the likelihood that someone will be harmed by the hazard together with the severity of harm suffered. Risk also depends on the number of people exposed to the hazard.
- **Control measures/controls:** Control measures/controls are the precautions taken to ensure that the risk is eliminated or reduced. Following risk assessment, implementing control measures is a critical element of managing safety effectively. Control measures ensure, for instance, that equipment is safe and work activities are conducted in a safe manner. It is not enough to be aware of risk. Control measures must be put in place to eliminate or significantly reduce it.
- **Risk assessment:** A risk assessment is concerned with identifying the hazard, then estimating the severity and likelihood of harm arising from such a hazard. The employer can then put in place control measures to minimise the risk or weigh up whether he or she has taken enough precautions to prevent harm. All risk assessments will be written and included in the school's safety statement. Coláiste Muire uses the templates available from the HAS to complete the risk assessment process and will follow the HAS's 3 step process when carrying out risk assessments:
 - Step 1 Identify the hazard
 - Step 2 Assess the risk in proportion to the hazard

- Step 3 Identify and implement the appropriate control measures to eliminate the hazard or reduce the risk

In many cases the most appropriate person to carry out a risk assessment of a classroom is the individual teacher using the classroom as he/she is most familiar with the environment and activities being undertaken. Risk assessments will be reviewed and revised at the beginning of each new academic year or as new equipment, systems, personnel or other significant changes occur. All completed risk assessments will be stored in the relevant file in the Principal's office. In addition to risk assessments, all practical rooms have safety rules (Appendix B) which are displayed in the relevant classrooms.

School trips

Risk assessments will be carried out for all school activities that occur both in the school and off-campus. These include sports events, field trips and school tours. Coláiste Muire's Trips & Outings policy outlines the measures taken when planning and executing a school trip/outing. When conducting a risk assessment for a school activity, particular care will be given to the nature and variety of school trips.

Emergency Procedures

First Aid

The provision of first aid equipment required by legislation is provided in accordance with First Aid Regulations 1993, contained in Part IX of the General Application Regulations 1993. First Aid Boxes are located in the:

- School Gym
- Secretary's Office
- Home Economics Kitchen
- Woodwork Room

A check will be carried out regularly to identify any replacement stocks needed. Following this check, a list of stocks required will be purchased. The restocking of the first aid boxes will be the responsibility of administration.

Procedures to be followed in the event of student illness are detailed in Appendix D.

First Aiders

Coláiste Muire has a team of trained First Aid personnel but also relies on the medical treatment by local GPs and at local hospitals where appropriate. Children are brought to Sligo General Hospital, where deemed necessary.

Following an accident requiring first aid treatment, an accident report form is completed. In the event of a serious injury the ambulance service must be called, the Principal is notified and a full accident investigation is carried out. The following staff have first aid training:

Aoife O'Malley, Orla Cryan, Michelle McDermott, Kate Connelly, Mary Kilcoyne, Yvonne Carty, Charles O'Connor

Names of certified occupational First Aiders are:

Charles O'Connor, Yvonne Carty

Refresher training is provided every three years.

Emergency/ Fire Procedures

All staff underwent fire safety training on 31st August 2022 and are certified for 3 years. All staff have been briefed on the School's Evacuation procedures (Appendix C) and are responsible for the safe evacuation of their respective class and themselves. Evacuation routes and assembly points have been identified for all areas. Maps detailing the escape routes will be prepared and will be located in each room and on corridors.

Evacuation drills take place at least twice a year or more often if required. Employees are reminded to familiarise themselves with the procedures so that a fast and effective evacuation of the premises can be complied in the event of an emergency.

All emergency exits are clearly marked and unobstructed at all times. Emergencies identified include fire, gas, leak, and bomb scare. Teachers will receive instructions on using fire equipment.

New teachers and employees will receive basic fire training and will be instructed on the following:

- Policy on smoking, electrical equipment etc. and how to raise the alarm.
- Actions to be taken on discovering a fire.
- Location and use of escape routes.
- The evacuation procedure.
- Assisting disabled people, visitors and others during evacuation.
- Location and use of fire extinguishers.

A Fire Register will be kept in the Principals' Office. The Fire Register will include company details, specific duties for members of staff, a log of fire procedure notices and fire drills, an inventory of firefighting equipment, details of the fire alarm system, a record of staff instruction/training and a maintenance/test/inspection schedule.

List Of Emergency Phone Numbers

AGENCY	CONTACT NUMBERS
Garda	071 9189500
Hospital	071 9171111
Fire Brigade	071 911 1403 / 1404 / 1413
Local GPs	Ballymote Primary Care Centre 071 919 1803 Ballymote Family Practice 071 919 1800 Gurteen Family Practice 071 9182110
Mental Health Service, Sligo/Leitrim, HSE Acute Inpatient Service	8 Ballytivnan Road, Sligo, 071 9142111
Bereavement Counselling Service, Sligo/Leitrim and West Cavan	071 9155108
Family Resource Centre Ballymote	071 9197818
Child and Family Mental Health Service (CAMHS)	071 9113960
Post Primary DES Inspectorate	01 8896553
NEPS Psychologist	087 4323853
NEPS	01 8892700
ASTI/TUI	ASTI: 01 6040160 TUI: 1850 453545
Clergy	Fr. James McDonagh, 0874104073
State Exams Commission	090 6442700
Employee Assistance Service	1800 411 057 SMS & WhatsApp: text 'Hi' to 087 369 0010

Fire Equipment

Fire Extinguishers are provided and correctly sited to meet safety requirements. These appliances are provided to deal with incipient fires. Trained personnel using these appliances will tackle small fires if they feel they can do so without endangering themselves.

All firefighting equipment is tested and serviced bi-annually by specialised contractors. In accordance with the recommendation of the appropriate Irish Standard for fire equipment, 20% of extinguishers will be discharged each year and relevant employees trained in the safe and efficient use of the equipment.

Fire extinguishing appliances are readily identified, with easy access and will be unobstructed at all times. The appliances must not be interfered with in any way.

Accident & Dangerous Occurrences

In the event of an accident or dangerous occurrence, first aid will be administered in the first instance where appropriate. The doctor and/or emergency services will be called and contact will be made with the with parent/guardian/family of the injured parties. Details of the accident and/or dangerous occurrence will be recorded in the accident reporting book in the secretary's office. The information recorded will be retained indefinitely and stored securely. When keeping or processing such records, in particular personal data relating to individuals, the requirements under the General Data Protection Regulation (GDPR) will be met by the school. The Board of Management will be kept informed of such accidents/dangerous occurrences and as required, the HAS, the State Claims Agency, the school's insurers or other bodies will be informed as appropriate.

Accident/Incident Reporting

All incidents no matter how trivial, whether to employees, students or visitors must be reported immediately to the Principal or in his/her absence, to the Deputy Principal. An Accident Report form is available for this purpose and must be completed by the person responsible for the area. In the case of school trips the teacher in charge is responsible for recording the accident on the appropriate form and for notifying the Principal. The information gathered will include:

- date and time of incident
- person injured or involved and relevant contact details recorded
- witnesses and relevant contact details recorded
- detail of the activity being undertaken at the time of the incident
- exact location of the incident and photographic evidence or plans of area if appropriate
- circumstances of the incident - detailed description and cause of the accident
- injuries sustained
- medical treatment administered, e.g. first-aid

- emergency services involved or called to scene of accident
- details of equipment and service records for same if equipment was involved in the accident
- details of notifier of accident, time, date

Recording of the above information will be necessary to monitor the progress of safety standards and to ensure that proper medical attention is given where required and as an aid in the identification of hazards so that the appropriate measures can be taken to prevent the accident from reoccurring.

Where an accident investigation is necessary, all employees are obliged to co-operate fully with such an investigation and to provide any information, which may be useful in establishing the circumstances leading up to the accident.

The Principal is responsible for completion, where necessary an IR.1 form where an employee is absent from work for more than three calendar days due to an industrial injury or illness, as it is a statutory requirement (S1 No. 44. 1993) that formal notice is given to the Health & Safety Authority.

Critical Incident Management

The management of critical incidents is detailed in the school's Critical Incident Management Policy.

School Transportation

Most students travel to school by school bus transport use designated bus drop off zones in the town to board and unboard school transport. Some students are dropped to school by car. The school has a traffic management system in place, whereby there is a one-way system in operation in the school grounds with clearly marked designated drop off zones. Parents are requested to use the one-way system at all times and to only use the drop-off zones for that purpose. Staff and visitors to the school are also required to use the one-way system for the purposes of health and safety. Staff have a designated car parking area and to further ensure the safety of students, staff and other users of the school, parents are not permitted to drive into this zone to drop off students. There are clearly marked signs to indicate this. A small number of students walk or cycle to school. There is a footpath from the school to the gate and pedestrian crossings on the grounds. The school has a covered bicycle rack for those cycling to school. The school encourages that where possible, students walk or cycle to school and if doing so, wears the appropriate reflective gear and/or helmets. Where driven or travelling on school transport, students are advised to wear safety belts at all times.

In addition to the school traffic management system, the school has established links with the Road Safety Authority, which runs Road Safety programmes with Transition Year students along with driving instruction and theory lessons.

Disciplinary Action

Where advice and persuasion fail to achieve compliance with health and safety rules, it is the basic policy of Coláiste Muire to take disciplinary action on the matter. The following basic procedure will be followed:

- Apart from any case of gross negligence of the Safety Regulations, which may warrant instant dismissal, the employee should be warned of any shortcomings and given a reasonable opportunity to put them right.
- Should it be necessary to take formal action a number of verbal warnings will be given. This warning will indicate the Specific Regulation, which has been breached, how it is to be rectified and the time limit in which it is to be achieved.
- A further warning will be given in writing, should the required improvement not result within the stated period, the matter will be referred to the School Board of Management.
- In any instances of alleged willful breaches of the Safety Regulation, the case will be investigated rapidly and fully. Depending on the results of the investigation, the employee will either be dismissed, given a written warning or will return to normal work.
- All warnings for breaches of Safety Regulations will be noted in the employees' file.
- Students will be disciplined according to the school's code of behaviour policy.

Instruction, Training & Supervision

The Board of Management undertake that all necessary training, instruction and information will be supplied to each employee to secure their safety and health in the work place. The primary responsibility for this rests with the management in co-operation with specialists as appropriate. Instruction and training will range from instruction for all staff on how to conduct risk assessments to training for smaller groups/individuals in first aid or the safe use of specialized equipment. Refresher courses will also be provided where needed.

The Board of Management recognizes that even with the best work arrangements, people may still need clearly defined safety procedures and instructions. For this reason, there is a commitment by Coláiste Muire to identify safety training needs, to carry out that training and to assess the competence of employees.

The Board of Management expects that all employees will co-operate in the training provided. Certain tasks require that strict safety procedures be followed. Where this arises the employees involved will receive special instructions by a competent person. It is essential that no person attempt a hazardous task without proper instruction and training. Both formal and on-the-job training programmes are designed so that employees become fully conscious of the need to work safely and have the necessary knowledge and skills to do so.

The Induction training programme includes information on the school's approach to safety and the safety procedures and requirements throughout the premises. On-the-job training focuses particularly on hazardous aspects of each job with a view to ensuring that employees are fully acquainted with the dangers arising from day-to-day tasks.

Training courses are provided on fire prevention and basic firefighting as necessary. These matters are also included in the induction training course of new employees. The designated teachers will be responsible for evacuation procedures.

Additional training courses are provided to meet specific needs as they arise from time to time. Such courses may be carried out in-house or at an appropriate outside agency.

On-going instruction and awareness-raising around safety, health and welfare occurs regular in the school environment to help foster a safety mind-set amongst all stakeholders. School assemblies, induction briefings, pre-class instruction and demonstration in practical areas are just some of the many on the ground instruction, training and supervision arrangements that are undertaken by school staff. The Health and Safety Authority provides an elearning portal with free on-line awareness-raising short courses along with courses for students which teachers can access in preparing students for the workplace.

Provision Of Practical And Safe Working Systems

It is the policy of the Board of Management, in conjunction with the Principal and/or relevant teachers, when purchasing new equipment, altering existing equipment or changing a system of work, to study such proposed purchases or changes to ensure so far as is practicable, that they are without significant risk.

Other systems of work include all routine work, electrical work, maintenance work and work by contractors on site. They will include consideration for the health and safety of visitors.

Personal Protective Equipment

It is the policy of Coláiste Muire that students and staff wear PPE where necessary and appropriate. In the case of practical subjects, e.g. woodwork and science, protective eyewear will be provided for use when required. In the case of home economics, students are required to wear a white coat for practical subjects.

Responsibility for ensuring that the equipment is used properly rests with the relevant subject teacher who will ensure that all students within his/her area of responsibility are properly instructed in the maintenance and use of protective clothing and safety equipment. Where the misuse of equipment and/or PPE occurs, this will be reported to the safety representative and/or the Principal/Deputy Principal and the misuse will be dealt with under the terms of the school's code of behaviour policy.

Where ancillary staff are using equipment, the appropriate training will be provided along with the necessary PPE.

Communication & Consultation

The school community will be made aware of the school's safety statement and its contents via the school website and for staff via the electronic staffroom and email. Staff will be invited to contribute to the risk assessment process and any review of the safety statement that takes place.

All staff will be made aware of the contents of the safety statement via an annual presentation at a full staff meeting and each staff member will be provided with an electronic copy of the safety statement and policy by email.

Information on safety, health and welfare will be communicated to all members of the school community using posters/displays/notices on safety, health and welfare matters. These notices will be located on staff/student notice boards, at school entrances/exit points, and in all rooms (regarding emergency procedures and fire exits and evacuation assembly points).

Monitoring, Review & Update

The management of safety, health and welfare is an ongoing process. The Board of Management will ensure that measures are taken throughout the school year to monitor and check that aspects of safety, health and welfare management are being carried out effectively. This will include:

- Agreed health and safety objectives and targets
- Monitoring of health and safety objectives for progress and continuous improvement
- Discussion of safety, health and welfare matters at Board of Management meetings
- Review of fire drills and evacuation exercises,
- Regular checking of safety features of potentially dangerous equipment in laboratories and workshops etc.
- Periodic inspections of fire safety equipment
- Risk assessment of new hazards as they arise and a record of new control measures identified and implemented
- Regular meetings of the safety committee where one exists
- Review of accidents and dangerous occurrences for lessons learned, corrective actions and after care of those involved
- Monitoring instruction, training and supervision arrangements in accordance with training needs identified.

Review of the safety statement will be approached in a similar fashion to all school policy. All stakeholders will be invited to contribute to the review of the safety statement. As the safety statement is a live working document, it will be reviewed on an annual basis. It will also be reviewed where changes

occur, such as staff changes, equipment replacement, or where new systems are put in place. The Safety Statement Checklist available from the HSA will be employed to assist the school in the process.

Documentation and Distribution of the Safety Statement

The Principal holds the master copy of the Safety Statement. Controlled copies of the Safety Statement will be issued to personnel as specified on the circulation list. It is school policy that all employees and students have access to those sections of the manual that are relevant to them. The Principal is responsible for the issue of new documentation and the retrieval and filing of obsolete documentation. To ensure that each copy of the safety Statement contains a record of all changes they will record changes or amendments on an amendment list, which will then be circulated to all on the circulation list.

Appendix A

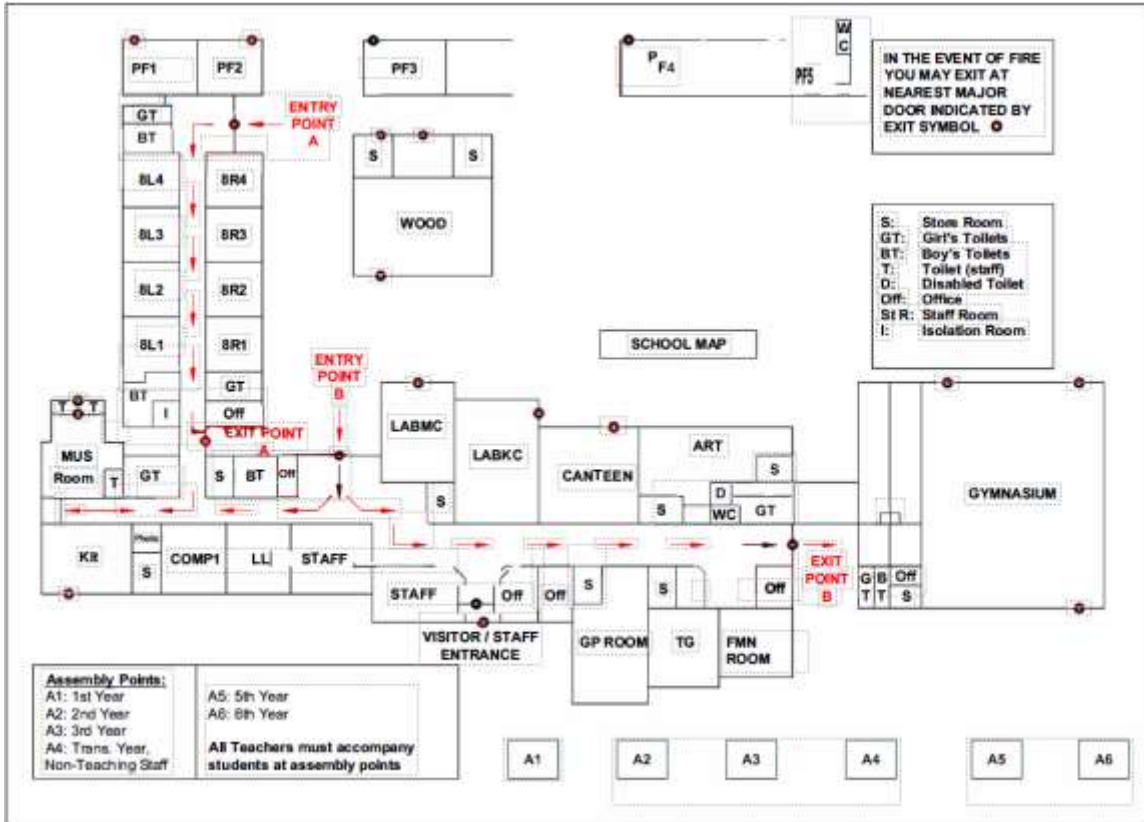

Appendix B

School Safety Rules

SAFETY RULES IN THE KITCHEN

- Before starting, tie up hair, remove all jackets and put on house coat.
- Leave all bags outside the kitchen in the cloakroom.
- Do not rush around the kitchen...walk.
- Turn all saucepan handles in towards the back of the hob.
- Take care when using or carrying sharp utensils around the kitchen.
- Do not trail flexes of appliances across the floor.
- Make sure that hands are dry when using electrical appliances.
- Switch off electrical appliances when finished using them.
- Always use oven gloves when removing dishes from the oven.
- Wipe up all spills as soon as they happen.
- Report all accidents immediately.

Hygiene Rules in the Kitchen

- Before starting, tie up hair, remove jewellery and put on apron.
- Wash hands with soap and warm water.
- Wipe all work surfaces with warm soapy water before and after preparing any food.
- Separate raw meat from cooked meat at all times.
- Always wash hands with soap and warm water after touching raw meat.
- Put all rubbish in a bin with a lid.
- Sweep the floor after preparing food.
- Make sure that the fan is on or a window open when cooking so that there is ventilation in the kitchen.
- Wash all utensils in warm soapy water, dry thoroughly and put away safely.
- Wipe up all spills as soon as they happen.

Personal Hygiene Rules in the Kitchen

- Hair tied back, hands washed, no nail varnish or jewellery.
- Clean white house coat worn at all times.
- Clean tea towel and dish cloth for all practical classes.
- Proper school uniform worn at all times, no jackets in the kitchen.
- In the interest of safety, no school bags in the kitchen during practical classes.
- Food containers are brought to practical class to bring home food cooked.
- Housekeepers are responsible for shopping for practical classes, storing it properly until needed and seeing that the kitchen is left clean and tidy after class.
- In the interest of safety, stools are placed under the tables at the end of each class.

Safety Rules in the Technical Graphics/Drawing Room

- Enter and leave the room in an orderly fashion.
- Sit at a designated position and remain there.
- All drawing instruments provided to remain on drawing boards.
- Care required when using compass “sharp point”.
- Report any damaged equipment to class teacher.
- No jackets permitted in the room.
- Ensure school bags are in a safe location.

Safety Rules in the M.T.W/Construction Studies Room

- Leave all bags and jackets at the back of the room.
- Do not rush around the room...walk.
- Keep your work area clean and free of dust and shavings.
- Tools that are not being used should be put away safely in the locker.
- Keep your clothing neat – ties, long hair, etc. can get caught in machinery.
- Spillages must be wiped up immediately.
- Wear safety equipment – goggles, glasses, masks, gloves, etc.
- Electrical equipment is dangerous. Use it only under supervision.
- Report all faulty equipment immediately.
- Do not interfere with others, especially when they are using tools or machines.
- If an accident occurs, report it immediately to your teacher.
- Do not continue working with an open wound, report it to the teacher.

Science Laboratory Daily Safety Checklist

- Safety equipment, chemicals, reagents and laboratory equipment must be stored properly.
- Benches and floors clean with no spills; waste paper, chemicals and broken glass in bins provided.
- Windows closed and locked.
- Animals made comfortable (food, water, ventilation, heat, clean cages).
- Dissecting instruments clean.
- Glassware clean.
- Water, gas, electricity, ovens, balances, centrifuges, fume cupboards, gas cylinders, etc. turned off (incubators may be left on overnight).
- Accident book up-to-date.
- Doors closed and locked.

Science Laboratory Weekly Safety Checklist

- As per the daily check list plus the items listed below.
- Fire extinguishers, eye wash bottles/showers, first aid kits, safety spectacles, safety screens, safety gloves and chemical spills clean up kit all in their places and in good working order.

Science Laboratory Once-a-Term Safety Checklist

- As per the daily and weekly check lists plus the items listed below.
- Fire drill procedures carried out.
- All electrical leads in good condition, plugs properly wired, sockets secure and not damaged.
- Bunsen burners and tubing in good condition.
- Fume cupboard ventilation adequate.
- Chemical storage shelves tidy and in proper order (no incompatible chemicals close to each other), no loose or damaged stoppers and out-of-date chemicals disposed of.
- Animal cages in a safe condition.
- Housekeeping good.
- Gas cylinders storage area safe, secure, clean and well ventilated.
- Accident book checked and "Term Accident Report" prepared for management.
- Update the emergency hazardous chemicals list held in the Principal's/Secretary's office.

Appendix C

Fire Drill Procedures

PROCEDURE FOR FIRE DRILL

1. Alarm

Anyone discovering an outbreak of fire should, without hesitation, sound the nearest fire alarm.

2. Calling the Fire Brigade

All outbreaks of fire, however small, or suspected fire, should be reported immediately to the Fire Brigade by dialing 999 or 112. This call should be made by the Principal/Deputy Principal/Secretary on having been alerted of the fire.

3. Evacuation

- On hearing the fire alarm, the Principal (or Deputy Principal in the absence of the Principal) should go to a predetermined conspicuous position in the place of assembly (roundabout) and remain there until a report has been received from all sections.
- The person in charge of a class should take a quick roll call or head count to ensure that everyone is present.
- The person in charge of a class should indicate to the class the route to be followed to the point of assembly. The nearest exit point is clearly displayed in all classrooms as well as the school map showing the assembly point. All assembly points are situated on the field facing the school.
- Assembly Point 1 = 1st Year Classes, their teachers and/or supervisors.
- Assembly Point 2 = 2nd Year Classes, their teachers and/or supervisors.
- Assembly Point 3 = 3rd Year Classes, their teachers and/or supervisors.
- Assembly Point 4 = Transition Year Classes, their teachers and/or supervisors, teachers and all other staff not scheduled for class at the time, any visitors to the school.
- Assembly Point 5 = 5th Year Classes, their teachers and/or supervisors.
- Assembly Point 6 = 6th Year Classes, their teachers and/or supervisors.
- Students should stand up and when instructed by the person in charge of the class leave the room in single file.
- The last person to leave the room should close the door.
- Students should leave the building in silence in order that any instructions given may be heard.
- Students must not run or pass others on the way.
- On stair cases, students should descend in single file.
- Students with disabilities should be accompanied by their Special Needs Assistant or class teacher.
- Teachers should follow at the rear of the class, with the class register, closing the door and windows behind them.
- No one should return to the building for anything that is forgotten. Anyone not actually in class when the alarm is sounded, e.g. in the toilets, etc. should go immediately direct to the assembly point and join their appropriate class or group.
- Students should remain at all times with their class group and teacher/supervisor.

4. Assembly and Roll Call

- The teacher should take a roll call or head count at the place of assembly.
- One teacher from each assembly point should inform the Principal/Deputy Principal if all students/persons in their charge have reported to the assembly area so that members of the Fire Brigade can be alerted if not present.
- Do not return to the building until instructions are given to do so.

5. Attacking the fire

- Circumstances will dictate whether firefighting operations should be attempted by an adult.
- Firefighting should always be secondary to life safety.

6. Visitors to the School and Staff not scheduled for classrooms

- All visitors to the school must sign in and out at the school office.
- They should be informed briefly of what to do in the event of a fire.
- Staff not scheduled for class should also sign in and out as appropriate.
- In the event of a fire, the secretary should take the visitors book to Assembly Point 4 and check that they have reported to the assembly point. The Secretary should check that all non-teaching staff members are present at the assembly point and advise the Principal/Deputy Principal of the results of the roll call.

NOTE: It is of the utmost importance that all teachers and/or supervisors bring an up to date copy of the roll book to class and call a roll at the beginning of each class. This is the responsibility of each class teacher, and in their absence, the supervisor. Alternatively, the roll may be checked using a mobile phone device and by logging into VSWare.

7. The Health & Safety Officer will:

- Organise at least 2 fire drills each academic year (in the first 2 weeks of term, each year group will be taken on a fire drill, followed by an announced fire drill for the whole school before October mid-term break. There will be an unannounced fire drill between November and Christmas break).
- Minute the date and time of fire drills along with details in the fire drill record book.

Fire Drill Record Sheet

Date of Drill	
Time of Drill	
Type of Drill	<input type="checkbox"/> Announced (Year Group) <input type="checkbox"/> Announced (Whole School) <input type="checkbox"/> Unannounced (Whole School)
Additional Details (any staff/students unaccounted for, issues that may have arisen during the drill)	
Signed	
Date	

Appendix D

Dealing with Student Illness

PROCEDURE FOR DEALING WITH STUDENT ILLNESS

Each member of staff has a duty of care to each student.

Procedure for dealing with accidents or illness of a student

- The student will inform their teacher if unwell. The teacher will contact the Deputy/Principal who will arrange for the student to be brought from the class and attended to.
- Alternatively, during class time the teacher may send the student to the secretary's office accompanied by another student named by the teacher. The accompanying student returns to class. The office staff will then inform Principal/Deputy Principal. If the office is unattended, students should report to the Principal/Deputy Principal directly.
- The Principal/Deputy Principal will talk to pupil re condition. A decision will then be made as to how serious the illness is and what action to take.
- In most cases, the pupil will be sent to the isolation room until ready to return to class.
- If the illness is deemed more serious the Parent/Guardian will be contacted. The student should not make contact with his/her Parent/Guardian by mobile phone prior to discussing his/her illness with a teacher/Principal/Deputy Principal/office staff.
- In the event of not being able to contact the Parents/Guardian, the pupil will be brought to the local doctor if necessary.
- During break and lunchtime the above procedure will also be applicable.
- In the case of suspected sprain, fracture etc. an appropriate person with first aid knowledge will be consulted and the following steps will be taken:
 1. Assess the seriousness of the case.
 2. Deal with it in so far as is possible.
 3. Inform Principal/Deputy Principal
 4. Contact Parent/Guardian to inform and to bring pupil to doctor.
 5. In an emergency the pupil is taken to the doctor.
 6. Complete Accident Report.
- In the case of an accident or illness on a school outing, the accompanying teacher will take the following steps:
 1. Assess the seriousness of the situation.
 2. If necessary, get medical aid.
 3. Inform Principal
 4. Inform Parents
 5. Complete Report
- Under no circumstances should medication be administered to a student unless the appropriate form of indemnity from the Administration of Medicines policy is on a student's file.
- All accidents/incidents, no matter how trivial, must be reported on, in the Accident Report Book available on the shelf beside the CCTV monitor in the Principal's Office.